

Technical specifications  
(1/4)

# Danesa

By JM Massana - JM Tremoleda



**Mobles114**

# Technical specifications

(2/4)

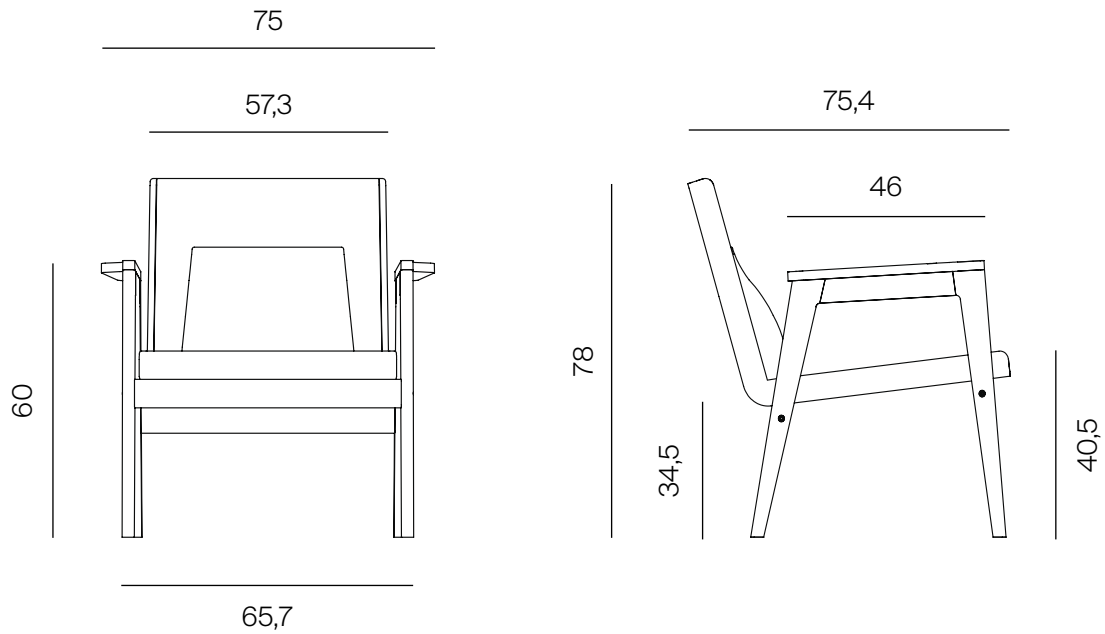

\*Metric unit: cm

## MATERIALS AND COLORS

### Structure (wood)



Oak

### Seat, backrest and cushion (upholstered)



Green  
68165



Mustard  
62057



Terracotta  
61151



Light Grey  
61104



Brown  
61103



Dark grey  
60021

\*Consult our textile catalogue to see all the finishes.

## PACKAGING

Units	Weight	Dimensions	Volume
1	13,27 kg	68X71X81 cm	0,39 m <sup>3</sup>

All packaging boxes are made of double recyclable cardboard.

# Technical specifications

(3/4)

## CERTIFICACIONES Y NORMATIVAS

**Resistencia uso público:** UNE-EN 15373:07

**Resistencia uso doméstico:** UNE-EN 1728:01

**Madera:** Forest Stewardship Council (FSC)

## MATERIALES Y ACABADOS

### Estructura

Butaca fabricada con madera maciza de roble. Todos los componentes que forman los laterales están unidos con clavijas y a la vez están encolados entre sí con cola sintética.

Los dos laterales y travesaños se unen mediante elementos mecánicos de acero. La estructura se fija a la carcasa con 4 tornillos DIN 912 M6X70.

Barnizada con barniz de base acuosa, sin colorear, para conservar el color natural de la madera. El procedimiento es fregado, dos capas de fondo y una última capa de barniz al agua. Con ello preservamos la butaca de la acción de agentes atmosféricos, y también ganamos resistencia.

### Asiento y respaldo

Carcasa interior de madera curvada, fabricada con prensa de alta frecuencia.

Tiene un espesor de 12 mm: 2 chapas de haya malla / contramalla en los exteriores y en el interior chapas de fresno.

Para el tapizado se usan diferentes espumas de poliuretano ignífugo que le dan una gran consistencia y confort.

Se incluye un cojín que mediante unos imanes internos, se puede colocar a diferente altura consiguiendo la comodidad que necesita el usuario.

No desenfundable.

La funda textil puede ser de distintos acabados, según la gama de Mobles 114.

## FABRIC Gabriel Cura

Technical characteristics:

Material: Post - costumer recycled polyester · polyester 98% · 2%

Weight: 420 g/lm · (13.55 oz/lin.yd.)

Width: 140 cm · (55")

Abrasion resistance: Rubs · BS EN 14465 · BS EN ISO 12947-2

(Martindale) 100,000. Double rubs wyzenbeek (ASTM D4157)

(Heavy Duty Upholstery) 100,000

Pilling: Scale 1-5 max. 5 · EN ISO 12945-2

Maintenance: Wash or dry cleaning. Flame retardant performance is dependent upon the foam used. Contain no Flame Retardant chemical.

Flammability: EN 1021 1&2 · BS 5852 0&1 · CA TB 117 - 2013

Will also pass other flammability standards.

40°C · Shrinkage max. 1,0%

60°C · Shrinkage max. 2,0%

## FABRIC Spardling Valencia

Technical characteristics:

Material: Vinyl / Urethane

Weight: 650 g/m<sup>2</sup>

Width: 137 cm · (53")

Abrasion resistance: >300.000 cycled (Martindale)

Pilling: Scale 1-5 max. 5 · EN ISO 12945 - 2

Maintenance: For light soiling, a solution of 10% household liquid dishsoap in warm water, applied with a soft damp cloth. Rinse with clean water and dry. Do not use with alcohol based cleaning agents.

Flammability: EN: 1021 1&2 · ES: UNE 23.727-90 1R/M.2 · FR: NF P 92-503/M2 DE: DIN 4102 B2 · AT: ÖNORM B 3825, Gruppe 1 - Schwerbrennbares IT: UNI 9175 (1987) / UNI 9175/FA1 (1994) Classe 1.1M (UNO I EMME) AT: ÖNORM A 3800 Teil 1, Qualmbildungsklasse Q1 - schwachqualmend IMO FTP 2010 Code MSC.307 (88) Part 8 3.1 & 3.2 · US: FMVSS 302 US: FAR 25/853 · ECE R118.02 (replaces Directive 95/28/CE) 6, 7 & 8 EN 71-2:2006+A1:2007 - Safety of Toys - Parte 2: Flammability

## FABRIC Gabriel Step

Technical characteristics:

Material: Trevira CS 100%

Weight: 470 g/lm · (15.16 oz/lin.yd.)

Width: 140 cm · (55")

Abrasion resistance: Rubs · EN ISO 12947-2 (Martindale) 100,000 Double rubs wyzenbeek (ASTM D4157-07) (Heavy duty upholstery) 100,000.

Pilling: Scale 1-5 max. 5 · EN ISO 12945 - 2

Maintenance: Wash or dry cleaning. Can be wiped with Virkon S, Actichlor Plus, Prime Source ren 93 or Ethanol (70-85%). Always follow the manufacturer's instructions and finish by wiping with a damp cloth. 60°C · Shrinkage max. 3,0% / 74°C · Shrinkage max. 5,0%

Flammability: CA TB 117 - 2013 BS 7176 Medium Hazard. AM 18 - NF D 60-013-(only for fabric) · DIN 4102 B1 · NFP 92-503/504/505 M1. BS EN 1021 1&2 · BS 5852 Part 1 0,1 Cigarette & match · BS 5852 Crib 5. Class Uno UNI 9175 Class 1 | EMME · ÖNORM B 3825 - B1 - 3800 - Q1 UK. FAR/JAR 25.853 (a) (i) (ii) · IMO MSC 307(88) Annex 1 part 8. MED Certificate IMO · DIN EN 13501 - 1 B-s1, d0. Will also pass other flammability standards. Flame retardant performance is dependent upon the foam used.

# Technical specifications

(4/4)

## FABRIC Gabriel Step Melange

Technical characteristics:

Material: Trevira CS 100%

Weight: 470 g/lm · (15.16 oz/lin.yd.)

Width: 140 cm · (55")

Abrasion resistance: Rubs · EN ISO 12947-2 (Martindale) 100,000

Double rubs wyzenbeek (ASTM D4157-07) (Heavy duty upholstery) 100,000.

Pilling: Scale 1-5 max. 5 · EN ISO 12945 - 2

Maintenance: Wash or dry cleaning. Can be wiped with Virkon S, Actichlor Plus, Prime Source ren 93 or Ethanol (70-85%). Always follow the manufacturer's instructions and finish by wiping with a damp cloth. 60°C · Shrinkage max. 3,0% / 74°C · Shrinkage max. 5,0%

Flammability: CA TB 117 - 2013 BS 7176 Medium Hazard. AM 18 - NF D 60-013-(only for fabric) ·

DIN 4102 B1 · NFP 92-503/504/505 M1. BS EN 1021 1&2 · BS 5852 Part 1 0,1 Cigarette & match · BS 5852 Crib 5. Class Uno UNI 9175 Class 1 | EMME · ÖNORM B 3825 - B1 - 3800 - Q1 UK. FAR/JAR 25.853 (a) (i) (ii) · IMO MSC 307(88) Anne x1 part 8. MED Certificate IMO · DIN EN 13501 - 1 B-s1, d0.

Will also pass other flammability standards. Flame retardant performance is dependent upon the foam used.

## FABRIC Gabriel Capture

Technical characteristics:

Material: New Zealand wool · polyamide 85% · 15%

Weight: 475 g/lm 3 (15.32 oz/lin.yd.)

Width: 140 cm · (55")

Abrasion resistance: Rubs · BS EN 14465 · BS EN ISO 12947 - 2 (Martindale) rubs 200,000. Martindale · ASTM D4966 - 02 (Heavy Duty Upholstery) 200,000

Pilling: Scale 1-5 max. 5 · EN ISO 12945 - 2

Maintenance: Dry cleaning

Flammability: EN 1021 1&2 · BS 5852 0&1 · CA TB 117 - 2013. Class Uno UNI 9175 Class 1 | EMME

Will also pass other flammability standards. Flame retardant performance is dependent upon the foam used. Contain no Flame Retardant chemical.

## FABRIC Kvadrat Remix 2

Technical characteristics:

Material: New wool · Nylon 90% · 10%

Weight: 415 g/lm · (14.63 oz/lin.yd.)

Width: 138 cm · (54")

Abrasion resistance: Rubs · EN ISO 12947 (Martindale) 100.000

Pilling: Note 4, EN ISO 12945

Maintenance: Vacuuming and dry cleaning

Flammability: AS/NZS 1530.3 · BS 5852 Crib 5 with treatment · BS 5852 part 1. EN 1021-1/2 · IMO FTP Code 2010: Part 8 · NF D 60 013 · NFPA 260. Önorm B1/Q1 · UNI 9175 1IM · US Cal. Bull. 117-2013.

No use of brominated flame retardants

## FABRIC Kvadrat Divina Melange

Technical characteristics:

Material: New wool 100%

Weight: 820 g/lin.m

Width: 150 cm · (59")

Abrasion resistance: Rubs · EN ISO 12947 (Martindale) 45.000

Pilling: Note 3, EN ISO 12945

Maintenance: Vacuuming and dry cleaning

Flammability: AS/NZS 1530.3, BS 5852 Crib 5, BS 5852 ignition source 3, BS 5852 part 1, BS 5867 part 2 type B, EN 1021-1/2, EN 13501, C-s1, d0, glued, NF D 60 013, NFPA 260, SN 198 898 5.3 with treatment \*, UNI 9175 1IM, US Cal. Bull. 117-2013, ÖNORM B1/Q1

## FABRIC Kvadrat Steelcut Trio 3

Technical characteristics:

Material: New wool · Nylon 90% · 10%

Weight: 770 g/lm · (27,16 oz/lin.yd.)

Width: 140 cm · (55")

Abrasion resistance: rubs · EN ISO 12947 (Martindale) 100.000

Pilling: Note 4, EN ISO 12945

Maintenance: Vacuuming and dry cleaning

Flammability: AS/NZS 1530.3 · AS/NZS 3837 class 2 · BS 5852 Crib 5 with treatment BS 5852 part 1 · DIN 4102 B2 · EN 1021-1/2 · IMO FTP Code 2010: Part 8 NF D 60 013 · NFPA 260 · Önorm B1/Q1 · SN 198 898 5.3 with treatment UNI 9175 1IM · US Cal. Bull. 117-2013

No use of brominated flameretardants

## MAINTENANCE

Clean with a damp cloth with water and neutral soap. Clarify and dry with a dry cloth. Avoid the use of abrasive products and stain removers containing solvents or greasy products.

Fabric: Follow manufacturer's instructions.